

TA-FUSION-P



Combined control & balancing valves

Pressure independent combined balancing and control valves with independent EQM characteristics

*Engineering
GREAT Solutions*

TA-FUS10N-P

These innovative pressure independent balancing and control valves for heating and cooling systems combine the key hydronic functions of balancing and control in one valve. Adjustable max. flow and inherent independent EQM characteristics allow correct valve sizing and optimum system controllability. The measuring points enable accurate measurement of flow, differential pressure, temperature and available differential pressure.

Key features

- > **Adjustable max. flow**
Adjustable Kvs technology allows setting to design flow.
- > **Independent, inherent EQM characteristic**
Proper EQM valve characteristic and high authority for all settings.
- > **Self-sealing measuring points**
Simple and accurate measurement for balancing, trouble shooting and power measurement.
- > **Actuators**
Valves and actuators supplied together ensuring optimum control performance and simplified selection.



Technical description – Valve

Application:

Heating and cooling systems.

Functions:

Control (EQM)
Differential pressure control
Pre-setting (max. flow)
Measuring (ΔH , T, q)
Shut-off (for isolation during system maintenance)
Flushing (of the system)

Dimension:

DN 32-150

Pressure class:

DN 32-50: PN 16
DN 65-150: PN 16 and PN 25

Differential pressure (ΔpV):

Max. differential pressure (ΔpV_{max}):
800 kPa = 8 bar
Min. differential pressure (ΔpV_{min}):
DN 32-50: 15 kPa = 0,15 bar
DN 65-80: 25 kPa = 0,25 bar
DN 100-125: 30 kPa = 0,30 bar
DN 150: 40 kPa = 0,40 bar
(Valid for position 10, fully open. Other positions will require lower differential pressure, check with the software TA Select.)
 ΔpV_{max} = The maximum allowed pressure drop over the valve, to fulfill all stated performances.
 ΔpV_{min} = The minimum recommended pressure drop over the valve, for proper differential pressure control.

Recommended flow range:

The flow (q_{max}) can be set within the range [m^3/h]:
DN 32: 0,88 - 4,21
DN 40: 1,01 - 6,19
DN 50: 2,71 - 11,1
DN 65-2: 9,40 - 24,2
DN 80-2: 13,6 - 36,8
DN 100: 27,8 - 68,0
DN 125: 45,6 - 120
DN 150: 78,1 - 207
 q_{max} = m^3/h at each setting and fully open valve plug.

Lift:

20 mm

Rangeability:

>100 (for all recommended settings)

Leakage rate:

Tight sealing

Characteristics:

Independent EQM.

Temperature:

Max. working temperature: 120°C

Min. working temperature: -20°C

Media:

Water or neutral fluids, water-glycol mixtures.

(For other media contact IMI Hydronic Engineering.)

Material:

DN 32-50:

Valve body: AMETAL®

Valve plug: AMETAL®

Seat seal: EPDM/Stainless steel

Spindle seal: EPDM O-ring

O-rings: EPDM

Valve insert: AMETAL®/PPS/PTFE

Δp insert: Stainless steel/PPS

Membrane: HNBR

Springs: Stainless steel

Spindle: Stainless steel

DN 65-150:

Valve body: Ductile iron EN-GJS-400

O-rings: EPDM

Valve plug: Stainless steel

Seat seals: EPDM/Stainless steel

Plug mechanisms: Stainless steel and brass

Membrane: EPDM

Δp spring: Stainless steel. DN 150 painted steel.

Screws and nuts: Stainless steel

AMETAL® is the dezincification resistant alloy of IMI Hydronic Engineering.

Marking:

DN 32-50: TAH, IMI, DN, PN, DR, serial No and flow direction arrow.

DN 65-150: TAH, IMI, DN, PN, Kvs, T_{min}/T_{max} , serial number, valve body material and flow direction arrow, label.

CE-marking:

DN 65-125: CE

DN 150: CE 0062 *

*) Notified body.

Surface treatment:

DN 32-50: Non treated

DN 65-150: Electrophoretic painting.

Connection:

DN 32-50:

Female thread according to ISO 228. Thread length according to ISO 7-1.

Female thread Rc according to ISO 7-1.

Male thread according to ISO 228.

DN 65-150:

Flanges according to EN-1092-2, type 21. Face to face length according to EN 558 series 1.

Valve characteristics

DN 32-150

Nominal valve characteristic for all recommended settings.

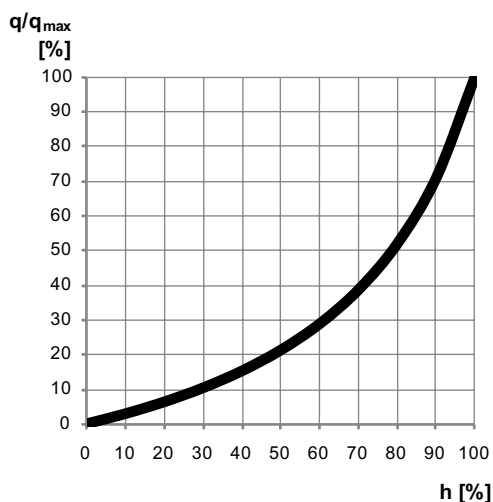

Measuring accuracy

Maximum flow deviation at different settings

DN 32-50

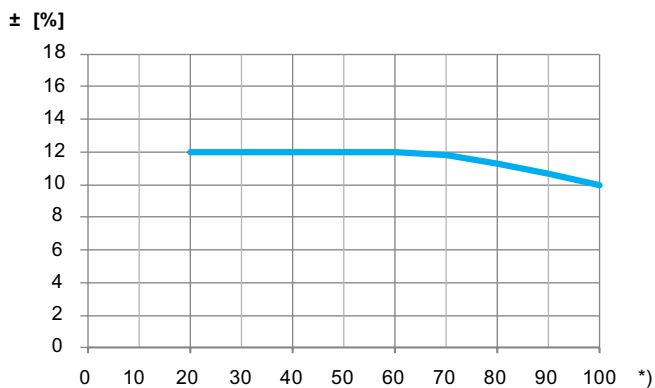

DN 65-150

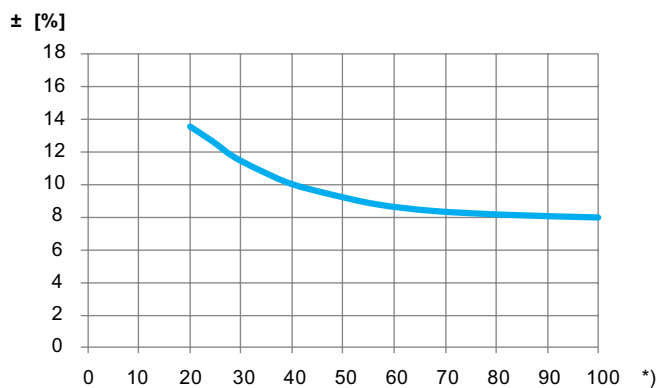

Correction factors

The flow calculations are valid for water (+20°C). For other liquids with approximately the same viscosity as water ($\leq 20 \text{ cSt} = 3^\circ \text{E} = 100 \text{ S.U.}$), it is only necessary to compensate for the specific density. However, at low temperatures, the viscosity increases and laminar flow may occur in the valves. This causes

a flow deviation that increases with small valves, low settings and low differential pressures. Correction for this deviation can be made with the software TA Select or directly in our balancing instruments.

Noise

In order to avoid noise in the installation the valve must be correctly installed and the water de-aerated.

Actuators

A wide range of high performance proportional actuators are available from IMI Hydronic Engineering (e.g. 24V, 230V, fail safe) to provide accurate modulating or 3-point control, when used together with combined balancing and control valves. See "Selection tables".

For more details on actuators, see related technical leaflet "TA-MC Actuators" or contact IMI Hydronic Engineering.

Sizing

Example

Flow is 10 m³/h, available Δp_V is 20 kPa and control signal (input signal) is 0-10 VDC.

1. Go to sizing diagram.
2. Draw a straight horizontal line from 10 m³/h, which will cross the setting bars for all valves which fit the application. In this case DN 50 setting 8,8, DN 65-2 setting 7,7.
3. Check that the available Δp_V is within the working range (between min. and max. allowed Δp_V). In this case, the Δp_V is 20 kPa which is out of range for DN 65 (min. $\Delta p_V=25$ kPa valid for setting 10, other settings will require slightly lower Δp_V , this can be checked with the software TA Select).
4. Choose the smallest option (with some safety margin). In this case DN 50 is preferable.
5. Go to the selection tables to select the correct valve and actuator combination. In this case article number 22202-031050.

Sizing diagram

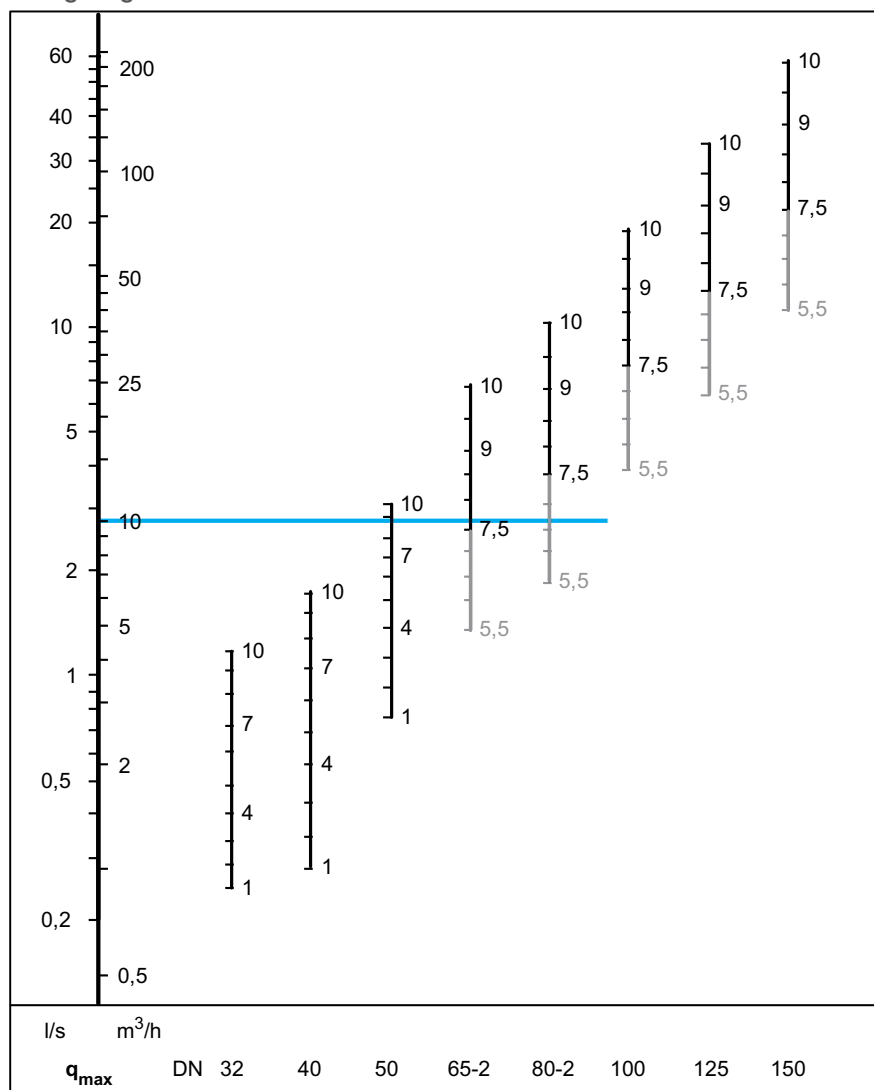

DN	Differential pressure Δp_V [kPa]	
	Min.	Max.
32-50	15	800
65-80	25	800
100-125	30	800
150	40	800

DN 65-150: Recommended setting range 7.5–10.

Selection tables

Maximum recommended pressure drop (ΔpV) for valve and actuator combination

The maximum recommended pressure drop over the valve and actuator combination for close off (ΔpV_{close}) and to fulfill all stated performances (ΔpV_{max}).

DN	TA-MC55Y/TA-MC55	TA-MC100	TA-MC100FSE/FSR
	[kPa]	[kPa]	[kPa]
32	800	800	800
40	800	800	800
50	800	800	800
65	800	800	800
80	800	800	800
100	800	800	800
125	800	800	800
150	–	800	800

ΔpV_{close} = The maximum pressure drop that the valve can close against from an opened position, with a specified force (actuator) without exceeding stated leakage rate.

ΔpV_{max} = The maximum allowed pressure drop over the valve, to fulfill all stated performances.

The codes in the selection tables are for different sets of valve size (DN) and type of actuator. Valves and actuators supplied together ensures optimum control and simplified selection. For other combinations order valve and actuator separately, see "Articles – Valves" and "Articles – Actuators".

For more details on actuators, see related technical leaflet "TA-MC Actuators" or contact IMI Hydronic Engineering.

Article number: 22202-xxxxxx

To get the complete article number, simply add the code stated below according to your required set.

Example: 22202-031032

Product codes in *italics* are with additional actuator functionalities.

DN	PN	Flow range [m ³ /h]	TA-MC55Y	TA-MC55	TA-MC55	TA-MC100	TA-MC100
			Input signal: ¹⁾	Output signal: ¹⁾	Supply voltage:	Fail safe:	Input signal: ¹⁾
			0(2)-10 VDC / 0(4)-20 mA	3-point	3-point	0(2)-10 VDC / 0(4)-20 mA and 3-point	0(2)-10 VDC / 0(4)-20 mA and 3-point
			0-10 VDC	0-10 VDC	0-10 VDC	0-10 VDC (0(4)-20 mA) ²⁾	0-10 VDC (0(4)-20 mA) ²⁾
			24 V	24 V	230 V	24 V	230 V
			No	No	No	No	No
32	16	0,88 - 4,21	031032	011032	021032	<i>041032</i>	<i>051032</i>
40	16	1,01 - 6,19	031040	011040	021040	<i>041040</i>	<i>051040</i>
50	16	2,71 - 11,1	031050	011050	021050	<i>041050</i>	<i>051050</i>
65-2	16	9,40 - 24,2	032065	012065	022065	<i>042065</i>	<i>052065</i>
65-2	25	9,40 - 24,2	033065	013065	023065	<i>043065</i>	<i>053065</i>
80-2	16	13,6 - 36,8	032080	012080	022080	<i>042080</i>	<i>052080</i>
80-2	25	13,6 - 36,8	033080	013080	023080	<i>043080</i>	<i>053080</i>
100	16	27,8 - 68,0	3)	3)	3)	042100	052100
100	25	27,8 - 68,0	3)	3)	3)	043100	053100
125	16	45,6 - 120	3)	3)	3)	042125	052125
125	25	45,6 - 120	3)	3)	3)	043125	053125
150	16	78,1 - 207	–	–	–	042150	052150
150	25	78,1 - 207	–	–	–	043150	053150

1) Invertable input and output signal

2) Output signal: 0(4)-20 mA on request (accessory), please contact IMI Hydronic Engineering.

3) See "Articles – Valves" and "Articles – Actuators".

DN 32-50: Female threaded

DN 65-150: Flanged

With fail safe actuators

			TA-MC100 FSE	TA-MC100 FSR	TA-MC100 FSE	TA-MC100 FSR
Input signal:			0(2)-10 VDC / 0(4)-20 mA and 3-point	0(2)-10 VDC / 0(4)-20 mA and 3-point	3-point	3-point
Output signal:			0(2)-10 VDC 0(4)-20 mA	0(2)-10 VDC 0(4)-20 mA	0-10 VDC	0-10 VDC
Supply voltage:			24 V	24 V	230 V	230 V
Fail safe:			Extending (closing)	Retracting (opening)	Extending (closing)	Retracting (opening)
DN	PN	Flow range [m ³ /h]				
32	16	0,88 - 4,21	081032	091032	101032	111032
40	16	1,01 - 6,19	081040	091040	101040	111040
50	16	2,71 - 11,1	081050	091050	101050	111050
65-2	16	9,40 - 24,2	082065	092065	102065	112065
65-2	25	9,40 - 24,2	083065	093065	103065	113065
80-2	16	13,6 - 36,8	082080	092080	102080	112080
80-2	25	13,6 - 36,8	083080	093080	103080	113080
100	16	27,8 - 68,0	082100	092100	102100	112100
100	25	27,8 - 68,0	083100	093100	103100	113100
125	16	45,6 - 120	082125	092125	102125	112125
125	25	45,6 - 120	083125	093125	103125	113125
150	16	78,1 - 207	082150	092150	102150	112150
150	25	78,1 - 207	083150	093150	103150	113150

DN 32-50: Female threaded

DN 65-150: Flanged

q_{max} values

	Position									
	1	2	3	4	5	6	7	8	9	10
DN 32	880	1 030	1 210	1 440	1 730	2 180	2 590	3 170	3 730	4 210
DN 40	1 010	1 240	1 560	1 990	2 460	3 040	3 790	4 610	5 410	6 190
DN 50	2 710	3 320	4 050	4 900	5 890	6 910	7 850	8 910	10 200	11 100

	Position									
	5.5	6	6.5	7	7.5	8	8.5	9	9.5	10
DN 65-2	4 850	5 880	6 900	8 190	9 400	11 400	13 600	15 900	19 500	24 200
DN 80-2	6 650	8 150	9 400	11 100	13 600	16 200	19 400	23 800	29 500	36 800
DN 100	14 000	16 600	19 700	23 400	27 800	32 900	39 500	46 000	56 500	68 000
DN 125	23 000	27 600	33 000	39 300	45 600	55 100	66 600	80 600	98 500	120 000
DN 150	40 200	47 500	56 200	66 200	78 100	93 800	113 000	137 000	170 000	207 000

 q_{max} = l/h at each setting and fully open valve plug.

DN 65-150: Recommended setting range 7.5–10.

Installation

Application examples

2-way direct circuit

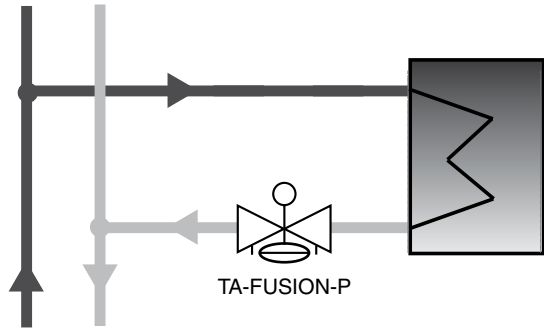

Injection circuit

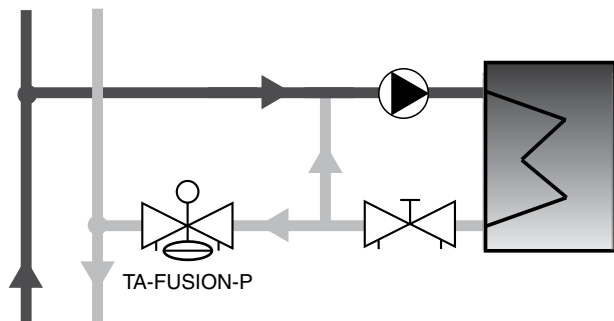

Normal pipe fittings

Avoid mounting taps and pumps immediately before or after the valve.

Installation recommendation for accurate measurement due to distortion of fully developed turbulent flow profile.

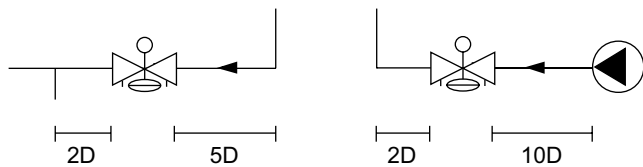

Flow direction

DN 32-50

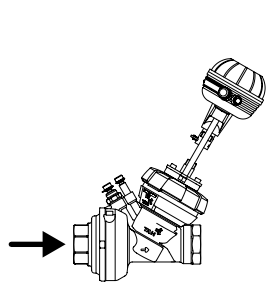

DN 65-150

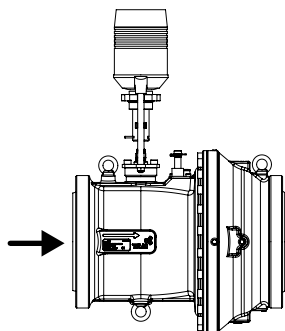

Installation of actuator

Approx. 140 mm of free space is required above the actuator.

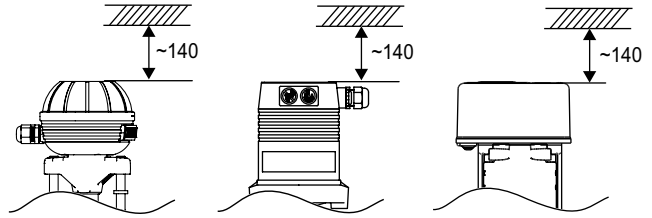

Enclosure class

Automatic operation: IP 54

(Manual operation TA-MC55: IP 30)

Note: Read carefully the installation instruction of the actuator.

TA-MC55Y, TA-MC55, TA-MC100

DN 32-50

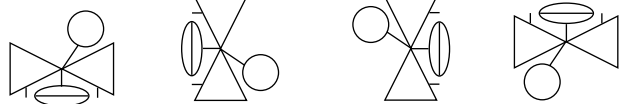

DN 65-150

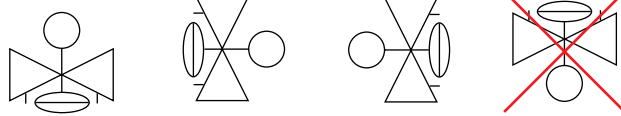

TA-MC100 FSE/FSR

DN 32-50

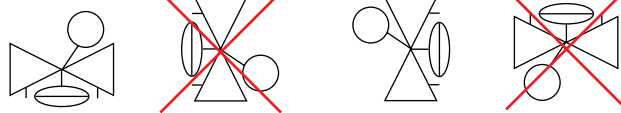

DN 65-150

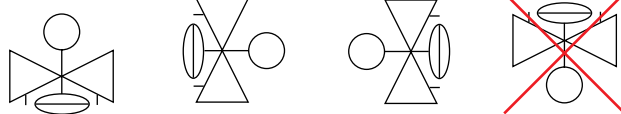

Operating function DN 32-50

Setting DN 32-50

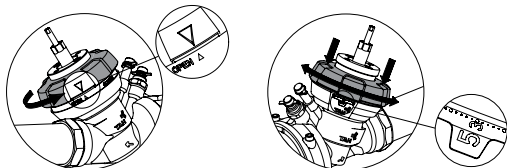

1. Open the valve **fully** with the handwheel.
2. Press the handwheel downwards and turn to desired value, e.g. 5.3.

Shut-off DN 32-50

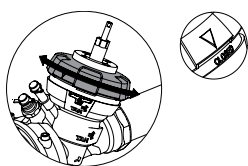

1. Turn the handwheel to "Closed".

Turn the handwheel to "Open" when re-opening the valve.

Flushing of the system DN 32-50

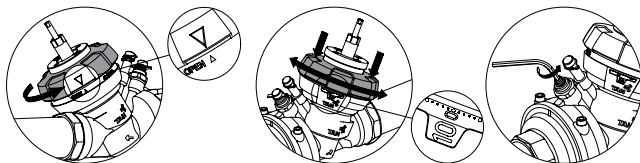

1. Open the valve fully with the handwheel.
2. Open the setting fully (position 10).
3. Deactivate the Δp part by opening the flushing spindle fully (anticlockwise).

After flushing, close the flushing spindle and set the valve to previous setting.

Venting DN 32-50

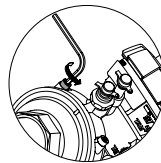

1. To vent the membrane chamber, open the topmost venting screw. **NOTE!** Max. 2 turns opening.

Measuring q DN 32-50

Connect IMI Hydronic Engineering balancing instrument to the measuring points. Input the valve type, size and setting and the actual flow is displayed.

Measuring ΔH DN 32-50

Close the valve according to "Shut-off", deactivate the Δp part according to "Flushing".

Connect IMI Hydronic Engineering balancing instrument to the measuring points and measure.

Important! The valve must be re-opened **fully and the Δp part activated** after the measurement is completed.

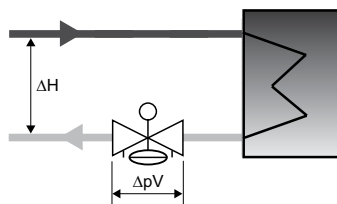

NOTE!

Ensure that the actuator is disengaged from the valve spindle during all operating functions described above, except venting.

Operating function DN 65-150

Setting DN 65-150

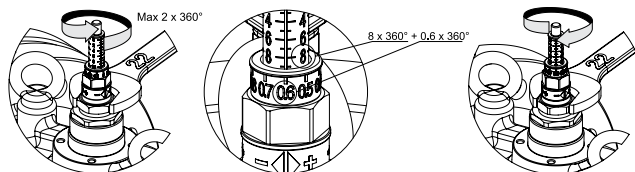

1. Release the fixing nut.
2. Turn the setting screw to desired value on the scale, e.g. 8.6.
3. Tighten the fixing nut.

Shut-off DN 65-150

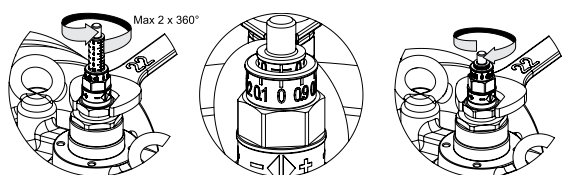

1. Release the fixing nut.
2. Turn the setting screw clockwise to stop (position 0 ± 0.5).
The presetting is visible on the setting scale.
3. Tighten the fixing nut.

Open to **previous setting** when re-opening the valve.

Flushing of the system DN 65-150

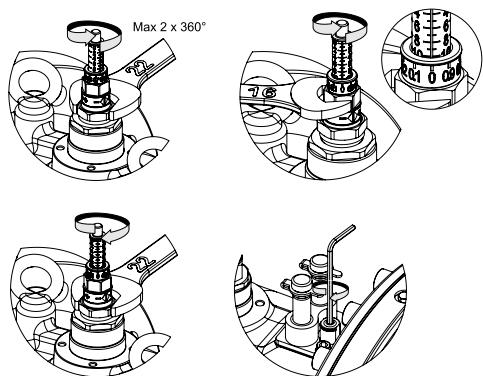

1. Release the fixing nut.
2. Turn the setting screw to fully open (position 10).
3. Tighten the fixing nut.
4. Deactivate the Δp part by closing the flushing spindle fully (clockwise).

After flushing, open the flushing spindle and set the valve to previous setting.

Venting DN 65-150

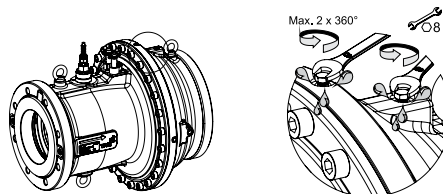

1. To vent the membrane chamber, open the topmost venting screw. **NOTE!** Max. 2 turns opening.

Measuring q DN 65-150

Connect IMI Hydronic Engineering balancing instrument to the measuring points. Input the valve type, size and setting and the actual flow is displayed.

Measuring ΔH DN 65-150

Close the valve according to “Shut-off”, deactivate the Δp part according to “Flushing”.

Connect IMI Hydronic Engineering balancing instrument to the measuring points and measure.

Important! The valve must be re-opened to **previous setting** and the **Δp part activated** after the measurement is completed.

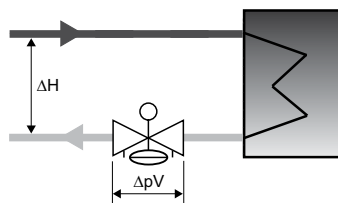

NOTE!

Ensure that the actuator is disengaged from the valve spindle during all operating functions described above, except venting.

Articles – Sets

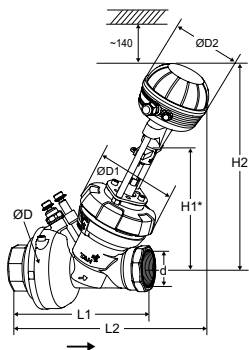

DN 32-50 Female threads

Threads according to ISO 228

0(2)-10 VDC / 0(4)-20 mA, 24 V (TA-MC55Y)

DN	d	D	D1	D2	L1	L2	H1*	H2	q _{max} [m ³ /h]	Kg	EAN	Article No
PN 16												
32	G1 1/4	130	128	109	213	333	186	326	4,21	8,0	5901688821329	22202-031032
40	G1 1/2	130	128	109	218	332	186	326	6,19	8,0	5901688821350	22202-031040
50	G2	130	128	109	226	340	190	330	11,1	8,5	5901688821381	22202-031050

3-point, 24 V (TA-MC55)

DN	d	D	D1	D2	L1	L2	H1*	H2	q _{max} [m ³ /h]	Kg	EAN	Article No
PN 16												
32	G1 1/4	130	128	109	213	333	186	326	4,21	8,0	5901688821305	22202-011032
40	G1 1/2	130	128	109	218	332	186	326	6,19	8,0	5901688821336	22202-011040
50	G2	130	128	109	226	340	190	330	11,1	8,5	5901688821367	22202-011050

3-point, 230 V (TA-MC55)

DN	d	D	D1	D2	L1	L2	H1*	H2	q _{max} [m ³ /h]	Kg	EAN	Article No
PN 16												
32	G1 1/4	130	128	109	213	333	186	326	4,21	8,0	5901688821312	22202-021032
40	G1 1/2	130	128	109	218	332	186	326	6,19	8,0	5901688821343	22202-021040
50	G2	130	128	109	226	340	190	330	11,1	8,5	5901688821374	22202-021050

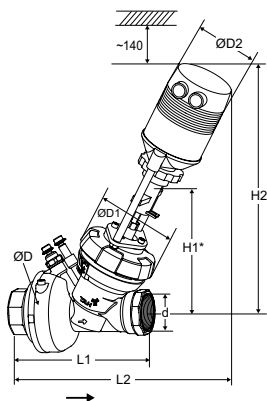

0(2)-10 VDC / 0(4)-20 mA and 3-point, 24 V (TA-MC100) ¹⁾

DN	d	D	D1	D2	L1	L2	H1*	H2	q _{max} [m ³ /h]	Kg	EAN	Article No
PN 16												
32	G1 1/4	130	128	103	213	380	186	398	4,21	9,0	5901688821398	22202-041032
40	G1 1/2	130	128	103	218	380	186	398	6,19	9,0	5901688821411	22202-041040
50	G2	130	128	103	226	384	190	402	11,1	9,5	5901688821435	22202-041050

0(2)-10 VDC / 0(4)-20 mA and 3-point, 230 V (TA-MC100) ¹⁾

DN	d	D	D1	D2	L1	L2	H1*	H2	q _{max} [m ³ /h]	Kg	EAN	Article No
PN 16												
32	G1 1/4	130	128	103	213	380	186	398	4,21	9,0	5901688821404	22202-051032
40	G1 1/2	130	128	103	218	380	186	398	6,19	9,0	5901688821428	22202-051040
50	G2	130	128	103	226	384	190	402	11,1	9,5	5901688821442	22202-051050

¹⁾ Actuators with additional functionalities, such as position switches, output signal 0(4)-20 mA, see related technical leaflet "TA-MC Actuators".

*) Height to the spindle top.

→ = Flow direction

For maximum ΔpV_{close} , see "Selection tables".

Valve and actuator are individually packaged for easy handling on site.

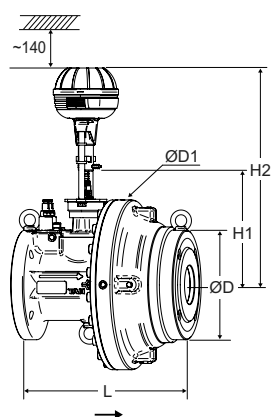
**DN 65-150 With flanges**

Flanges according to EN-1092-2, type 21.

0(2)-10 VDC / 0(4)-20 mA, 24 V (TA-MC55Y)

DN	D	D1	L	H1*	H2	q _{max} [m ³ /h]	Kg	EAN	Article No
PN 16									
65-2	185	286	290	205	365	24,2	47	5901688821626	22202-032065
80-2	200	290	310	205	365	36,8	54	5901688821718	22202-032080
PN 25									
65-2	185	286	290	205	365	24,2	47	5901688821657	22202-033065
80-2	200	290	310	205	365	36,8	54	5901688821749	22202-033080

3-point, 24 V (TA-MC55)

DN	D	D1	L	H1*	H2	q _{max} [m ³ /h]	Kg	EAN	Article No
PN 16									
65-2	185	286	290	205	365	24,2	47	5901688821602	22202-012065
80-2	200	290	310	205	365	36,8	54	5901688821695	22202-012080
PN 25									
65-2	185	286	290	205	365	24,2	47	5901688821633	22202-013065
80-2	200	290	310	205	365	36,8	54	5901688821725	22202-013080

3-point, 230 V (TA-MC55)

DN	D	D1	L	H1*	H2	q _{max} [m ³ /h]	Kg	EAN	Article No
PN 16									
65-2	185	286	290	205	365	24,2	47	5901688821619	22202-022065
80-2	200	290	310	205	365	36,8	54	5901688821701	22202-022080
PN 25									
65-2	185	286	290	205	365	24,2	47	5901688821640	22202-023065
80-2	200	290	310	205	365	36,8	54	5901688821732	22202-023080

1) Actuators with additional functionalities, such as position switches, output signal 0(4)-20 mA, see related technical leaflet "TA-MC Actuators".

*) Height to the spindle top.

→ = Flow direction

For maximum $\Delta p_{V_{close}}$, see "Selection tables".

Valve and actuator are individually packaged for easy handling on site.

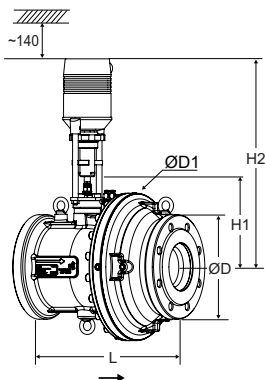

0(2)-10 VDC / 0(4)-20 mA and 3-point, 24 V (TA-MC100) ¹⁾

DN	D	D1	L	H1*	H2	q _{max} [m ³ /h]	Kg	EAN	Article No
PN 16									
65-2	185	286	290	205	438	24,2	48	5901688821770	22202-042065
80-2	200	290	310	205	438	36,8	55	5901688821831	22202-042080
100	220	310	350	221	438	68,0	62	5901688822135	22202-042100
125	250	344	400	221	438	120	85	5901688822197	22202-042125
150	285	380	480	251	457	207	121	5901688823712	22202-042150
PN 25									
65-2	185	286	290	205	438	24,2	48	5901688821794	22202-043065
80-2	200	290	310	205	438	36,8	55	5901688821855	22202-043080
100	235	310	350	221	438	68,0	62	5901688822159	22202-043100
125	270	344	400	221	438	120	85	5901688822210	22202-043125
150	300	380	480	251	457	207	121	5901688823729	22202-043150

0(2)-10 VDC / 0(4)-20 mA and 3-point, 230 V (TA-MC100) ¹⁾

DN	D	D1	L	H1*	H2	q _{max} [m ³ /h]	Kg	EAN	Article No
PN 16									
65-2	185	286	290	205	463	24,2	48	5901688821787	22202-052065
80-2	200	290	310	205	463	36,8	55	5901688821848	22202-052080
100	220	310	350	221	463	68,0	62	5901688822142	22202-052100
125	250	344	400	221	463	120	85	5901688822203	22202-052125
150	285	380	480	251	482	207	121	5901688823736	22202-052150
PN 25									
65-2	185	286	290	205	463	24,2	48	5901688821800	22202-053065
80-2	200	290	310	205	463	36,8	55	5901688821862	22202-053080
100	235	310	350	221	463	68,0	62	5901688822166	22202-053100
125	270	344	400	221	463	120	85	5901688822227	22202-053125
150	300	380	480	251	482	207	121	5901688823743	22202-053150

1) Actuators with additional functionalities, such as position switches, output signal 0(4)-20 mA, see related technical leaflet "TA-MC Actuators".

*) Height to the spindle top.

→ = Flow direction

For maximum ΔpV_{close} , see "Selection tables".

Valve and actuator are individually packaged for easy handling on site.

Articles – Fail-safe sets, extending (closing)

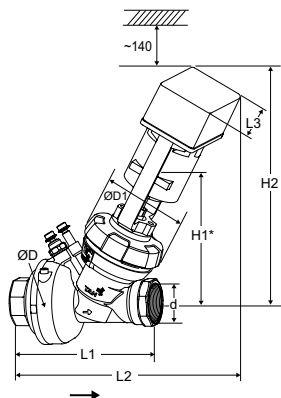

DN 32-50 Female threads Threads according to ISO 228

0(2)-10 VDC / 0(4)-20 mA and 3-point, 24 V (TA-MC100FSE)

DN	d	D	D1	L1	L2	L3	H1*	H2	q _{max} [m ³ /h]	Kg	EAN	Article No
PN 16												
32	G1 1/4	130	128	213	379	141	186	356	4,21	9,3	5901688821459	22202-081032
40	G1 1/2	130	128	218	379	141	186	356	6,19	9,3	5901688821497	22202-081040
50	G2	130	128	226	383	141	190	360	11,1	9,8	5901688821534	22202-081050

0(2)-10 VDC / 0(4)-20 mA and 3-point, 230 V (TA-MC100FSE)

DN	d	D	D1	L1	L2	L3	H1*	H2	q _{max} [m ³ /h]	Kg	EAN	Article No
PN 16												
32	G1 1/4	130	128	213	379	141	186	356	4,21	9,3	5901688821473	22202-101032
40	G1 1/2	130	128	218	379	141	186	356	6,19	9,3	5901688821510	22202-101040
50	G2	130	128	226	383	141	190	360	11,1	9,8	5901688821558	22202-101050

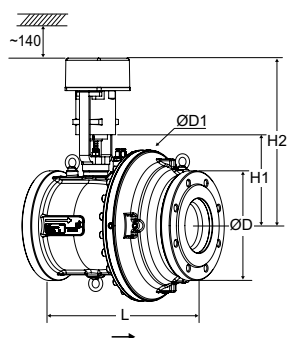

DN 65-150 With flanges Flanges according to EN-1092-2, type 21.

0(2)-10 VDC / 0(4)-20 mA and 3-point, 24 V (TA-MC100FSE)

DN	D	D1	L	H1*	H2	q _{max} [m ³ /h]	Kg	EAN	Article No
PN 16									
65-2	185	286	290	205	382	24,2	48	5901688821916	22202-082065
80-2	200	290	310	205	382	36,8	55	5901688822036	22202-082080
100	220	310	350	221	382	68,0	62	5901688822333	22202-082100
125	250	344	400	221	382	120	85	5901688822456	22202-082125
150	285	380	480	251	401	207	121	5901688823750	22202-082150
PN 25									
65-2	185	286	290	205	382	24,2	48	5901688821954	22202-083065
80-2	200	290	310	205	382	36,8	55	5901688822074	22202-083080
100	235	310	350	221	382	68,0	62	5901688822371	22202-083100
125	270	344	400	221	382	120	85	5901688822494	22202-083125
150	300	380	480	251	401	207	121	5901688823767	22202-083150

0(2)-10 VDC / 0(4)-20 mA and 3-point, 230 V (TA-MC100FSE)

DN	D	D1	L	H1*	H2	q _{max} [m ³ /h]	Kg	EAN	Article No
PN 16									
65-2	185	286	290	205	382	24,2	48	5901688821930	22202-102065
80-2	200	290	310	205	382	36,8	55	5901688822050	22202-102080
100	220	310	350	221	382	68,0	62	5901688822357	22202-102100
125	250	344	400	221	382	120	85	5901688822470	22202-102125
150	285	380	480	251	401	207	121	5901688823798	22202-102150
PN 25									
65-2	185	286	290	205	382	24,2	48	5901688821978	22202-103065
80-2	200	290	310	205	382	36,8	55	5901688822098	22202-103080
100	235	310	350	221	382	68,0	62	5901688822395	22202-103100
125	270	344	400	221	382	120	85	5901688822517	22202-103125
150	300	380	480	251	401	207	121	5901688823804	22202-103150

*) Height to the spindle top.

→ = Flow direction

For maximum $\Delta p_{V_{close}}$, see "Selection tables".

Valve and actuator are individually packaged for easy handling on site.

Articles – Fail-safe sets, retracting (opening)

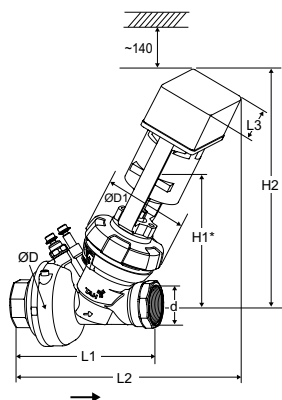

DN 32-50 Female threads Threads according to ISO 228

0(2)-10 VDC / 0(4)-20 mA and 3-point, 24 V (TA-MC100FSR)

DN	d	D	D1	L1	L2	L3	H1*	H2	q _{max} [m ³ /h]	Kg	EAN	Article No
PN 16												
32	G1 1/4	130	128	213	379	141	186	356	4,21	9,3	5901688821466	22202-091032
40	G1 1/2	130	128	218	379	141	186	356	6,19	9,3	5901688821503	22202-091040
50	G2	130	128	226	383	141	190	360	11,1	9,8	5901688821541	22202-091050

0(2)-10 VDC / 0(4)-20 mA and 3-point, 230 V (TA-MC100FSR)

DN	d	D	D1	L1	L2	L3	H1*	H2	q _{max} [m ³ /h]	Kg	EAN	Article No
PN 16												
32	G1 1/4	130	128	213	379	141	186	356	4,21	9,3	5901688821480	22202-111032
40	G1 1/2	130	128	218	379	141	186	356	6,19	9,3	5901688821527	22202-111040
50	G2	130	128	226	383	141	190	360	11,1	9,8	5901688821565	22202-111050

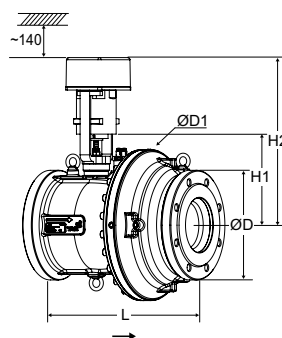

DN 65-150 With flanges Flanges according to EN-1092-2, type 21.

0(2)-10 VDC / 0(4)-20 mA and 3-point, 24 V (TA-MC100FSR)

DN	D	D1	L	H1*	H2	q _{max} [m ³ /h]	Kg	EAN	Article No
PN 16									
65-2	185	286	290	205	382	24,2	48	5901688821923	22202-092065
80-2	200	290	310	205	382	36,8	55	5901688822043	22202-092080
100	220	310	350	221	382	68,0	62	5901688822340	22202-092100
125	250	344	400	221	382	120	85	5901688822463	22202-092125
150	285	380	480	251	401	207	121	5901688823774	22202-092150
PN 25									
65-2	185	286	290	205	382	24,2	48	5901688821961	22202-093065
80-2	200	290	310	205	382	36,8	55	5901688822081	22202-093080
100	235	310	350	221	382	68,0	62	5901688822388	22202-093100
125	270	344	400	221	382	120	85	5901688822500	22202-093125
150	300	380	480	251	401	207	121	5901688823781	22202-093150

0(2)-10 VDC / 0(4)-20 mA and 3-point, 230 V (TA-MC100FSR)

DN	D	D1	L	H1*	H2	q _{max} [m ³ /h]	Kg	EAN	Article No
PN 16									
65-2	185	286	290	205	382	24,2	48	5901688821947	22202-112065
80-2	200	290	310	205	382	36,8	55	5901688822067	22202-112080
100	220	310	350	221	382	68,0	62	5901688822364	22202-112100
125	250	344	400	221	382	120	85	5901688822487	22202-112125
150	285	380	480	251	401	207	121	5901688823811	22202-112150
PN 25									
65-2	185	286	290	205	382	24,2	48	5901688821985	22202-113065
80-2	200	290	310	205	382	36,8	55	5901688822104	22202-113080
100	235	310	350	221	382	68,0	62	5901688822401	22202-113100
125	270	344	400	221	382	120	85	5901688822524	22202-113125
150	300	380	480	251	401	207	121	5901688823828	22202-113150

*) Height to the spindle top.

→ = Flow direction

For maximum ΔpV_{close} see "Selection tables".

Valve and actuator are individually packaged for easy handling on site.

Articles – Valves

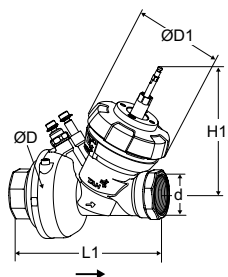
Female thread

Threads according to ISO 228

DN	d	D	D1	L1	H1*	q_{max} [m ³ /h]	Kg	EAN	Article No
PN 16									
32	G1 1/4	130	128	213	186	4,21	6,6	7318798638903	22202-001032
40	G1 1/2	130	128	218	186	6,19	6,6	7318798639009	22202-001040
50	G2	130	128	226	190	11,1	7,1	7318798639108	22202-001050

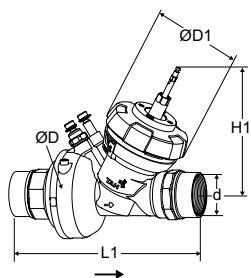
Female thread Rc

Threads according to ISO 7-1

DN	d	D	D1	L1	H1*	q_{max} [m ³ /h]	Kg	EAN	Article No
PN 16									
32	Rc1 1/4	130	128	279	186	4,21	7,1	7318794016200	22202-004032
40	Rc1 1/2	130	128	282	186	6,19	7,1	7318794016309	22202-004040
50	Rc2	130	128	303	190	11,1	8,0	7318794016408	22202-004050

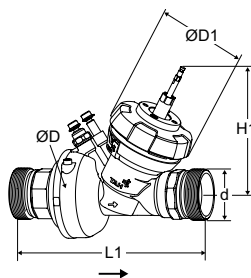
Male thread

Threads according to ISO 228

DN	d	D	D1	L1	H1*	q_{max} [m ³ /h]	Kg	EAN	Article No
PN 16									
32	G1 1/2	130	128	273	186	4,21	7,2	7318794016507	22202-005032
40	G2	130	128	280	186	6,19	7,2	7318794016606	22202-005040
50	G2 1/2	130	128	294	190	11,1	8,1	7318794016705	22202-005050

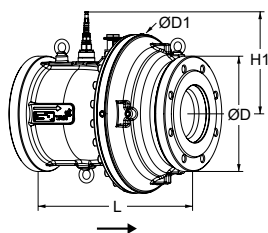
Flanged

Flanges according to EN-1092-2, type 21.

DN	D	D1	L	H1*	q_{max} [m ³ /h]	Kg	EAN	Article No
PN 16								
65-2	185	286	290	205	24,2	45	5901688827581	22202-002065
80-2	200	290	310	205	36,8	52	5901688827611	22202-002080
100	220	310	350	221	68,0	59	3831112529427	22202-002100
125	250	344	400	221	120	82	3831112529441	22202-002125
150	285	380	480	251	207	118	3831112529489	22202-002150
PN 25								
65-2	185	286	290	205	24,2	45	5901688827598	22202-003065
80-2	200	290	310	205	36,8	52	5901688827628	22202-003080
100	235	310	350	221	68,0	59	3831112529434	22202-003100
125	270	344	400	221	120	82	3831112529465	22202-003125
150	300	380	480	251	207	118	3831112529496	22202-003150

→ = Flow direction

All valves are delivered with adapters for TA-MC55Y, TA-MC55, TA-MC100 and TA-MC100 FSE/FSR.

Articles – Actuators

Type	EAN	Article No
TA-MC55Y	3831112506510	61-055-003
TA-MC55/24	3831112527812	61-055-001
TA-MC55/230	3831112506503	61-055-002
TA-MC55/115		61-055-302
TA-MC100/24	3831112511675	61-100-001
TA-MC100/230	3831112500235	61-100-002
TA-MC100/115		61-100-302
TA-MC100FSE/24	3831112512122	61-100-101
TA-MC100FSR/24	3831112512146	61-100-201
TA-MC100FSE/230	3831112512139	61-100-102
TA-MC100FSR/230	3831112512153	61-100-202

NOTE: No additional adapters needed.

Accessories and more details on actuators, see related technical leaflet “TA-MC Actuators” or contact IMI Hydronic Engineering.

Adapters for other actuators

For actuator	EAN	Article No
DN 65-150		
Siemens SAX-P, SQV-P	3831112530928	22214-000001

Accessories

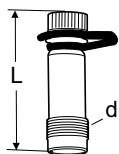

Measuring point

For DN 65-150.

d	L	EAN	Article No
M14x1	44	7318792813207	52 179-014
M14x1	103	7318793858108	52 179-015

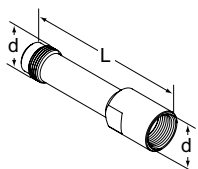

Extension for measuring point M14x1

Suitable when insulation is used.
For DN 65-150.

d	L	EAN	Article No
M14x1	71	7318793969507	52 179-016

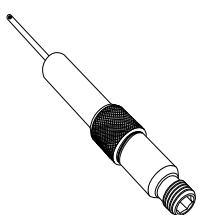

Measuring point

Extensions 60 mm.
Can be installed without draining of the system.
For all dimensions.

L	EAN	Article No
60	7318792812804	52 179-006

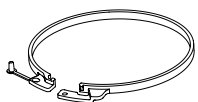

Tamper proof ring

For locking of set Kv_{max} .

For DN	EAN	Article No
32-50	7318794001800	22107-000001

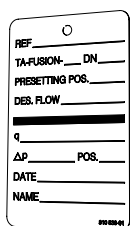

Identification tag

EAN	Article No
7318794001701	22107-000002

Insulation

See related insulation instruction under "Products & Solutions" on www.imi-hydronic.com or contact IMI Hydronic Engineering.

Actuators accessories

See related technical leaflet "TA-MC Actuators" or contact IMI Hydronic Engineering.

Connections for DN 32-50

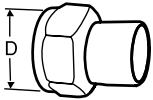

Welding connection

Swivelling nut
Max 120°C

Valve DN	D	Pipe DN	EAN	Article No
32	G1 1/2	32	7318792748806	52 009-032
40	G2	40	7318792748905	52 009-040
50	G2 1/2	50	7318792749001	52 009-050

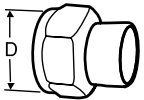

Soldering connection

Swivelling nut
Max 120°C

Valve DN	D	Pipe Ø	EAN	Article No
32	G1 1/2	35	7318792749803	52 009-535
40	G2	42	7318792749902	52 009-542
50	G2 1/2	54	7318792750007	52 009-554

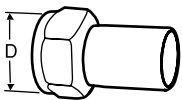

Connection with smooth end

For connection with press coupling
Swivelling nut
Max 120°C

Valve DN	D	Pipe Ø	EAN	Article No
32	G1 1/2	35	7318793811004	52 009-335
40	G2	42	7318793811103	52 009-342
50	G2 1/2	54	7318793811202	52 009-354

